

**UWL**<sup>TM</sup>  
The art of superyacht lighting

# QT-LED

## INSTALLATION GUIDE

[UNDERWATERLIGHTS.COM](http://UNDERWATERLIGHTS.COM)

THE QT-LED RANGE IS DESIGNED AND MANUFACTURED BY UNDERWATERLIGHTS LIMITED

# QT-LED

## INSTALLATION GUIDE

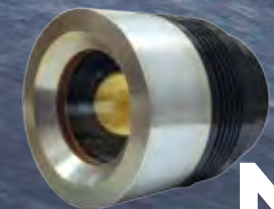
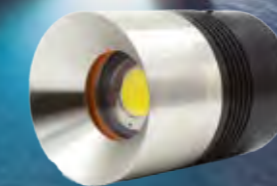
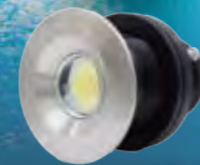
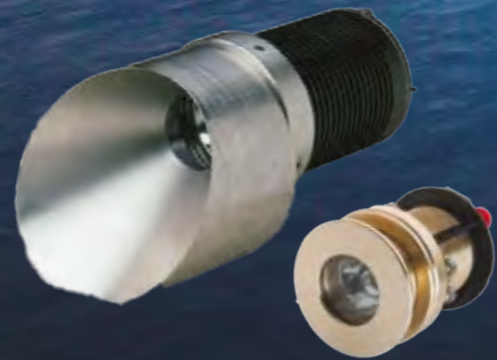

**NEW**

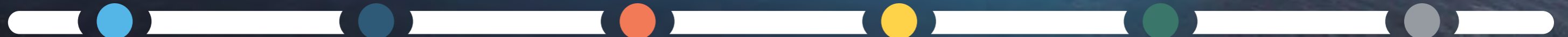

**1991**

The launch of the worlds first underwater light for yachts - The Bulleyt.

**2005**

The Bulleyt is superseded by the UL Ti MATE range

**2009**

We launched our first UL Ti MATE light with LED

**2016**

QT LED launched using latest technology with flat LED chip producing 100% more lumens

**2022**

QTS 75 launched using our unique design allowing universal adjustment for ease of installation.

**2024**

QTE 140 is flush mounted to the hull and has a larger aperture for wider beam angle and universal adjustment.

[WWW.UNDERWATERLIGHTS.COM](http://WWW.UNDERWATERLIGHTS.COM)

THE QT-LED RANGE IS DESIGNED AND MANUFACTURED BY UNDERWATERLIGHTS LIMITED

## IMPORTANT









**IMPORTANT:** Please read the instructions completely before proceeding with the installation, for full manual please visit [www.underwaterlights.com](http://www.underwaterlights.com). Failure to follow the instructions may invalidate your warranty.

This manual contains important information about the installation, operation and safe use of this product.

This information should be given to the owner and/ or operator of this equipment.







### QT-80-Ti Install

-  QT-80-Ti is a 'through hull' submersible marine light and is delivered ready for installation. Maintenance is carried out from inside the hull and the light is suitable for hulls with a maximum thickness of 62mm.
-  Qualified/Approved personnel must be used to carry out installation.
-  Before cutting a 61mm hole in the hull, check the wall thickness is not greater than 62mm. The location of the holes must be below the water line. After finishing the hole surface, check the 'Body' (1) can be inserted.
-  Note for cored hulls - after cutting, the exposed surfaces of the hole must be finished to form a solid surface through it. Thus protecting the internal core of the hull, the wall thickness of the hole should not be less than 5mm (0.25")
-  Apply 3M-4200FC sealant to the 'Body' (1) flange. Slide the body into the hole and from inside the hull put the 'compensating ring' (3) on and screw the 'securing ring' (4) up hand tight. Gently tighten the 'adjustment screws' (7) so the compensating ring is flush to the hull and the sealant has flowed completely around the flange and hull.
-  Do NOT overtighten the bolts as this will squeeze the sealant from the surfaces. Allow the sealant to solidify and remove the surplus. Finally tighten the bolts to 4Nm/3ft.lbs.
-  It is not necessary to remove the 'heatsink' (2) when carrying out installation.
-  To remove the 'heatsink' (2) unscrew the 'clamp ring' (5). There are two M5 tapped holes to use if the heatsink is difficult to remove.

#### TECHNICAL SPECIFICATION

Supply voltage	12/24VDC
Power	20w maximum current @ 11vdc is 2 amps 40w maximum current @ 11vdc is 4 amp
LED Driver	Integral
LED	Cool white or blue
Body Material	Titanium & 5083 aluminium had black anodised
LED Lamp Life	20,000 hours

-  Before fitting the new 'heat sink' (2) ensure the barrel part of the 'body'(1) and lens is clean. Use silicone grease to lightly coat the 'heat sink' (2), 'clamp ring' (5) and sealing 'orings' (6). Slide the 'heat sink' (2) into the barrel and tighten the knurled 'clamp ring' (5) to secure the 'heat sink' (2) into the body. When the heatsink cannot be rotated the clamp ring has secured in place. If this is not done it will cause overheating of the LED, allow possible water/moisture ingress causing the light to fail and this is not covered under warranty.
-  After completing the installation procedure it is highly recommended to coat the 'body' (1) face with antifouling. The lights must also be bonded to the anodes or a cathodic protection system, if not done this will invalidate your warranty.
-  EARTHING LIGHT FOR CATHODIC PROTECTION - tighten the 'earth screw' (8) onto the 'securing ring' (4) so that it bites into the screwed barrel. Check there is continuity to the front face as this prevents galvanic corrosion.

-  Caution: do not operate the lights unless totally submerged.



Description Qt 80	Qty
1:Body/Face	1
2:Led Heat Sink	1
3:Compensating Ring	1
4:Securing Ring	1
5:Clamp ring	1
6:'O' Rings	2
7:Adustment screws	3
8:Earth screw	1

**EARTH SCREW  
ITEM 8**

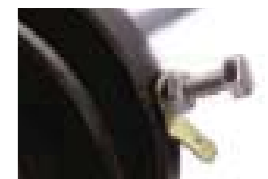

### Power and connection information for – QT80-Ti & QTS100 DC

(Part Number QTD-JUNCTION HUB)

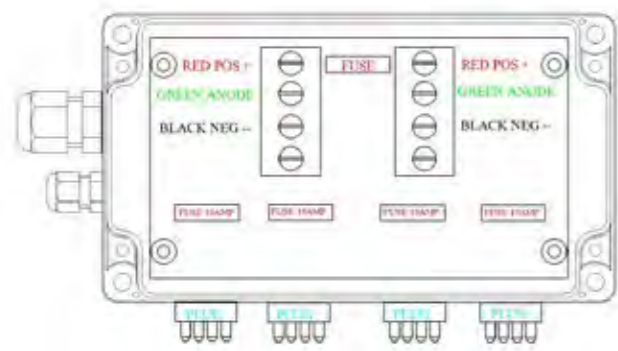

FOUR WAY FUSED AND SURGED PROTECTED PLUG AND PLAY ENCLOSURE

(Part Number QTP-FUSE 4-3)

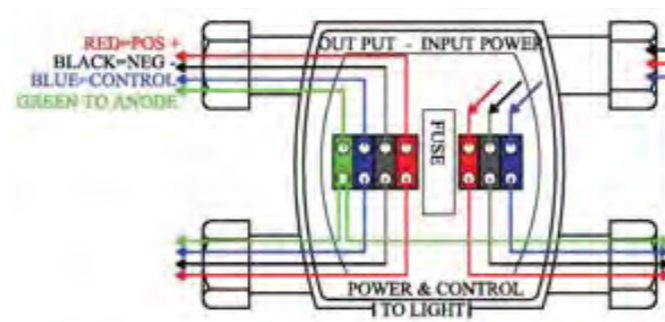

TWO WAY FUSED ENCLOSURE FROM EITHER SIDE - EARTH CONNECTED TO ANODE

The picture below shows a very important procedure in checking that the light is connected to the insert.

Using an ohm meter connect the light bezel to the anode.

The ohm value should be less than 1 ohm.

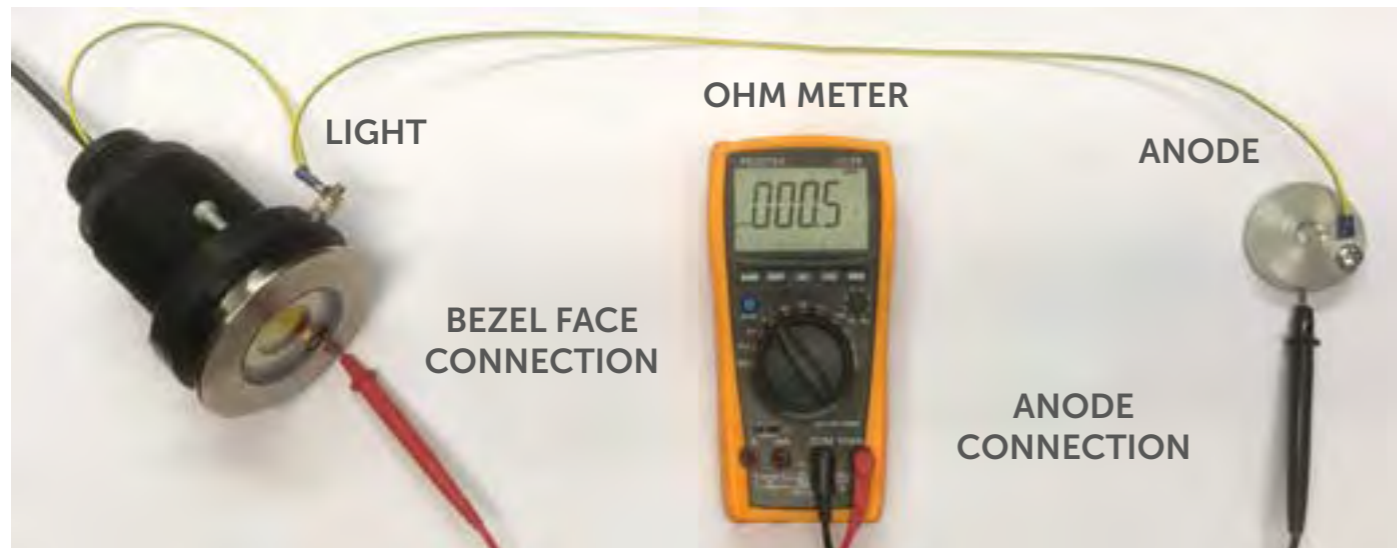

The four way/surge protected enclosure protects the power cable to the lights only. The lights are supplied with cable and a plug for easy connection. The earth cable has to be connected to the anode. **You are responsible to fuse the power supply cable.** See inside junction hub lid for instructions.

Lights supplied with no plug will require connection inside the two way connector as shown in the diagram.

The table below shows the lumen, power and current draw for each light at 12 and 24 volts and the fuse rating for each light when not using our enclosures. It also shows the supply amperage for each enclosure with the maximum amount of lights connected.

We do not supply the input cable. Please use the cable size list to select the correct cable. This supply cable must be fused for protection and the recommended **SUPPLY CABLE FUSE** is in the list below.

MODEL NUMBER	LUMEN OUTPUT	COLOUR	12 VDC SUPPLY POWER & DRAW CURRENT & FUSE RATING	24 VDC SUPPLY POWER & DRAW CURRENT & FUSE RATING	TWO WAY ENCLOSURE WITH 2 LIGHTS DRAW AMPS 12-24 VDC- SUPPLY CABLE FUSE	FOUR WAY ENCLOSURE WITH FOUR LIGHTS DRAW AMPS 12-24VDC- SUPPLY CABLE FUSE
QT-80-Ti-40	7000	Blue/White	40 watts-4 amps-10 amp	40 watts-2.0 amps- 10 amps	8.0 A-4.0 amps-10 amps	16 amps-8 amps-20 amps
QT-80-Ti-20	3,500	Blue/White	20 watts-2 amps-10 amp	20 watts-1 amps-10 amp	4.0 A- 2 amps-10 amps	8 amps-4 amps-20 amps
QTS-100-LP1W	14,000	White	N.A	90 watts-4 amps-10 amp	N.A-8 amps-10 amps	N.A-16 amps- 20 amps
QTS-100-LPW/B	10,000	Blue/White	80 watts-7 amps-10 amp	80 watts-3.5 amps-10 amp	N.A-7 amps-10 amps	28 amps-14 amps-30 amps

Standard and Metric Wire Comparison Table	CIRCUIT TYPE				CURRENT FLOW IN AMPS																			
	10% VOLTAGE DROP Non Critical		3% VOLTAGE DROP Critical		5A	10A	15A	20A	25A	30A	40A	50A	60A	70A	80A									
	0 to 20 ft	0 to 6.1 M	0 to 6 ft	0 to 1.8 M																				
Available Wire Size AWG	16	14	12	10	16 AWG	14 AWG	12 AWG	10 AWG	8 AWG	6 AWG	4 AWG	2 AWG	1 AWG	0 AWG	0 AWG									
Available Wire Size Metric	1.5	2.5	4	6	10	16	25	35	50	70	100	150	200	250	300									
LENGTH	30 ft	9.1 M	10 ft	3.0 M	50 ft	15.2 M	15 ft	4.6 M	65 ft	19.8 M	20 ft	6.1 M	80 ft	24.4 M	25 ft	7.6 M	100 ft	30.5 M	30 ft	9.1 M	130 ft	39.6 M	40 ft	12.2 M

\*If a second Hub is requested for installing more lights, please make sure you are using the correct cable suitable for the Amps drawn.

## Warranty Statement

Warranty Statement Underwater Lights Limited (UWL) stands by its products. In general terms, the company gives a full 2 year's manufacturer's warranty on all its products from the date of sale, provided that the products have been installed correctly per the installation instructions available on the website at: [www.underwaterlights.com](http://www.underwaterlights.com). To submit a claim, please read and follow the guides lines in the warranty statement below; Section 6: Making a claim. Please note, claims may be rejected if the troubleshooting guidelines are not completed, photographs of the unit and area where it is installed are not included with claim submission, or the problem is related to how and where the unit was installed. Please note that all metal parts corrode in salt water. The primary factors affecting corrosion are not directly related to our products and accordingly UWL cannot be held responsible for corrosion-related defects, this includes but is not limited to where water has been allowed to enter the cable as a result of immersion in water during the installation or improper sealing of connections. Please note corrosion will be particularly aggressive if installation and/or bonding has not been correctly undertaken; or if stray currents are active in the vicinity of the boat. (Claims will also be rejected if bonding of the units has not been installed). Claims will also be rejected if the units were found to be installed in an inappropriate position without prior approval from Underwater Lights LTD. As made clear on the installation sheet included with your lights original packaging, lights should not be installed pointing down where they can accumulate water. Underwater Lights LTD products are tested and approved to IPX8 protection from the front face ONLY. Submersion from behind may result in failure of equipment and is not covered by this warranty policy. The installer and operator must engage in preventative action to ensure the back of the light units located inside the boat do not become submerged at any time. Floods, pump failures and faulty hatch seals which lead to equipment failure is not covered by this warranty policy. Color variation commonly occurs within the LED manufacturing process. Whilst UWL makes every effort to match the color of any lights there may be a noticeable difference when installed next to existing lights. UWL does not warrant this color variation on lights. All UWL products must be connected to the anodes or cathodic protection system and checked to ensure there is good connection to the front face of the light. Failure to bond lights during install will invalidate the lights warranty. Information on bonding procedure is provided with your lights. All Underwater Lights products must be installed by qualified marine installers and certified electricians. No warranty will be honored if lights are damaged by improper installation either in terms of placement (see above) or sound electrical standards are not followed. Underwater Lights LTD can advise on light locations and simple circuit diagrams, however, we will not advise and therefore have no liability when it comes to installation by a 3rd party in relation to power distribution, electrical protection or installation in hazardous areas. UWL reserves the right to change the design, range and components without any prior notification either written or implied. The detailed terms and conditions of this warranty are set out below:

**1: WARRANTY OF QUALITY** 1.1 In the case of LED goods manufactured and sold by UWL, a company incorporated in England and Wales (registered number 2348038) and whose registered office is at The Great Dunton Forge, London Road, Dunton Green, Kent, United Kingdom, TN13 2DG (the "Goods" and the "Company", respectively), the Company warrants to the purchaser of the Goods (the "Buyer") Conditions and unless otherwise notified) upon delivery (whether installed or not). That (subject to the other provisions of these) The Goods supplied shall be of satisfactory quality within the meaning of the Sale of Goods Act of 1979. 1.2 the Company shall not liable for a breach of the warranty in Condition 1.1 unless: 1.2.1 the Buyer gives written notice of the defect to the Company, and to the carrier if the defect is as a result of damage in transit, within 14 days of the time when the Buyer discovers or ought to have discovered the defect; and 1.2.2 the Buyer has the obligation to provide all the requested information where is reasonably possible and provided a truthful statement of all information requested in relation to the claim. 1.2.3 the Buyer returns such Goods to the Company's place of business at the Buyers cost, regardless of the outcome of the claim. 1.2.4 the Company is given a reasonable opportunity after receiving the returned Goods for the examination to take place at the company's place of business. 1.3 the Company shall not be liable for a breach of the warranty in Condition 1.1 if: 1.3.1 the Buyer makes any further use of such Goods after giving such notice; or 1.3.2 the defect arises because the Buyer failed to follow the Company's oral or written instructions as to storage, transportation, installation, commissioning, modification, use or maintenance of the Goods or (if there are none) good trade practice; or the defect arises from the corrosion of metal parts or the failure of the Buyer to ensure that Goods are installed correctly, installed in approved locations, bonded correctly and that there are no active stray currents in the vicinity; or 1.3.3 the defect arises as a result of any default of, or caused by, the Buyer or (without limitation) as a result of misuse, abuse, improper installation, neglect, improper shipping by a party other than the Company; or 1.3.4 the Buyer alters, repairs or modifies such Goods without written consent of the Company; or 1.3.5 the defect arises due to a cause beyond the Company's reasonable control, such as: act of God, explosion, flood, tempest, re or accident, including without limitation lightning; war or threat of war, national emergency, sabotage, terrorism, insurrection, protest, riot, epidemic, civil disturbance or requisition; Acts, restrictions, regulations, by-laws, prohibitions or measures of any kind on the part of any governmental, parliamentary or local authority; import or export regulations or embargoes; strikes, lock-outs or other industrial actions or trade disputes (whether involving employees of the Company or of a third party); restraints or delays affecting carriers or inability or delay in obtaining supplies of adequate or suitable materials; or power failure or breakdown in machinery. 1.3.6 where the Company has notified the Customer directly of in service modification(s) deemed necessary to further protect the Goods from damage have not been followed. 1.3.7 where a claim has been made where the Goods ownership is in dispute. 1.3.8 where the parts were not purchased from an authorized outlet.

1.3.9 where the goods were purchased via the internet from the United States but were not shipped to an address or installed in the United States. 1.4 Subject to Conditions 1.2 and Condition 1.3, if any of the Goods do not conform with the warranty in Condition 1.1 the Company shall at its option repair or replace such Goods (or the defective part) without charge for labor or parts or refund the price of such Goods at the original purchase price. The Company shall pay for the return transportation to the Buyer of such repaired or replaced Goods. 1.5 Any Goods replaced shall belong to the Company and any such repaired or replacement Goods shall be guaranteed on these terms for the unexpired portion of the warranty period of the warranty in Condition 1.1.

**2: LIMITATION OF LIABILITY** 2.1 These Conditions set out the entire financial liability of the Company (including any liability for the acts or omissions of its employees, agents and sub-contractors) to the Buyer in respect of: 2.1.1 any breach of these Conditions; 2.1.2 any defect in the Goods; 2.1.3 any use made or resale by the Buyer of any Goods, or of any product incorporating any of Goods; and 2.1.4 any representation, statement or tortious act or omission including negligence arising or in connection with the contract with the Buyer. 2.2 All warranty, conditions and other terms implied by both UK law are, to the fullest extent permitted by law, excluded from the contract with the Buyer. 2.3.1 nothing in these conditions excludes or limits the liability of the Company; 2.3.1 for death or personal injury caused by the Company's negligence; 2.3.2 under both UK law; 2.3.3 for any matter which it would be illegal for the Company to exclude or attempt to exclude its liability; or 2.3.4 for fraud or fraudulent misrepresentation. 2.4 Subject to the above Condition 2.3: 2.4.1 the Company's total liability in contract, (including without limitation negligence or breach of statutory duty), misrepresentation, restitution or otherwise, arising in connection with the performance or contemplated performance of the contract with the Buyer or (without limitation) in respect of the Goods shall be limited to the original purchase; and 2.4.2 the Company shall not be liable to the Buyer for any pure economic loss, loss of profits, loss of business, loss of contracts, damage to property, depletion of goodwill or otherwise, in each case whether direct, indirect, or consequential, or any claims for consequential whatsoever (however caused) which arise out of or in connection with the contract with the Buyer or (without limitation) the Goods.

**3: THIRD PARTY RIGHTS** 3.1 No term of any Contract formed between the Buyer and the Company shall be enforceable by virtue of the Contracts (Rights of Third Parties) Act 1999 by any person that is not a party to it.

**4: APPLICABLE LAW** 4.1 Each of (a) the sale of the Goods to the Buyer, (b) these conditions, and (c) any disputes or claims arising there from or in connection therewith shall be governed by and construed in accordance with the law of England; and the Buyer and the Company irrevocably agree that the Courts of England have exclusively jurisdiction to settle any dispute or claim that arises out of or in connection with the foregoing.

**5: GREY MARKET INTERNET POLICY** 5.1 Grey marketed products continue to be a threat to our worldwide distribution and dealer network. In order to proactively discourage this activity by Internet resellers of our product, UWL will not honor the warranty of products purchased via the grey market through internet resellers. The following notice is stated on UWL's warranty cards, website and all internet sellers will be required to post the same notice. **WARRANTY NOTIFICATION:** UWL products purchased by an end-user from a United States dealer via the Internet are covered by this warranty, only if the products are delivered and installed within the United States. The warranty is void if the product is delivered or installed outside the United States. Proof of purchase and installation will be required. Product installed by OEM will be warranted when shipped as part of a new boat package.

**6: MAKING A CLAIM** 6.1 Irrespective of how the products were fitted or by whom, if you discover that there may be a problem with the products you must notify either your local dealer or UWL within 14 days. 6.1.1 When you discover a problem, we ask that the products are not used until they are fixed. This will minimize any further damage. We recommend the product be disconnected from its power source to prevent accidental use and covering any open connections, of the with an electrically safe and waterproof solution to prevent water entering the cable or product. 6.1.2 If a claim is accepted the part will be replaced on a "like for like basis". No refunds will be given. 6.1.3 If you require a part urgently from us, you would be required to purchase a new one from us. You then have a maximum of 30 days to return the faulty part to us. We will investigate and if the product has a problem due to our manufacturing, we will provide a full refund. If you do not think that you can return the part to us within the 30 days please contact the Service Manager. If the product is not returned within the time limit without speaking to the Service Manager to obtain an extension to the 30 days, the claim will be closed and no refund given. 6.1.4 If we are unable to find a problem with the part, we will inform you of the outcome. We can provide guidance to possible reasons for the fault. UWL is not liable for or can fix problems with equipment & installations that are not purchased from UWL. The returned product can be returned to you at your request. 6.1.5 If you feel unhappy with any part of the process of claiming please let us know. 6.1.6 Please take pictures at every stage of the process. Claims sent without pictures will be automatically rejected until photographs of the lights and area it is installed in are supplied. 6.2 Products supplied and fitted by a dealer: 6.2.1 If you had the products installed by one of our dealers, we ask that you contact them and ask that they check the installation and establish the cause of the problem prior to making a claim. If you are not local to the installer, please visit our website ([www.underwaterlights.com](http://www.underwaterlights.com)) to find the authorized dealer closest to you. Many problems are due to environmental contamination, issues with the installation or electrical issues which are external to the lighting system and can be resolved without the need for the removal of the product or initiation of the warranty procedure. An example for environmental contamination, make sure your lenses are free of growth when conducting your tests. 6.2.2 Locate your original purchase invoice for the products showing product purchased within last 2 years and contact the dealer you purchased the products and / or who fitted them. 6.2.3 Your dealer will contact us and together we will resolve your issues and together we will investigate the part. 6.2.4 If the problem is found not to be due to the manufacture of the product, repair or replacement will fall outside of this warranty coverage and the buyer will be liable for all costs. 6.2.5 If you require a part urgently from us, you would be required to purchase a new one from us. You then have a maximum of 30 days to return the faulty part to us. We will investigate and if the product has a problem due to our manufacturing, we will provide a full refund. If you do not think that you can return the part to us within the 30 days please contact the Service Manager. If the product is not returned within the time limit without speaking to the Service Manager to obtain an extension to the 30 days, the claim will be closed and no refund given. 6.2.6 If we are unable to find a problem with the part, we will inform you of the outcome. We can provide guidance to possible reasons for the fault. UWL is not liable for or can fix problems with equipment & installations that are not purchased from UWL. The returned product can be returned to you at your request. 6.3 Products supplied by a dealer but fitted by the Buyer: 6.3.1 If you installed the products yourself, before making contact we ask that you follow the troubleshooting chart for your product. When following the appropriate troubleshooting

ing chart, it is helpful to complete the appropriate warranty claim information sheet. Copies can be found in the troubleshooting section of the manual included with the product or alternatively it can be download from our website. 6.3.2 If after following the troubleshooting guide, you still believe that the problem still exists with our product you will need to contact the dealer that you purchased the product(s) from. If you are unable to do this you may contact any dealer / distributor in your local area (a list can be obtained either from our website ([www.underwaterlights.com](http://www.underwaterlights.com)) or by contacting our Head Office. 6.3.3 You will be required to provide the information recorded on the warranty claim information sheet and have the copy of your purchase invoice for the products along with pictures of the damaged unit and area it is located in. 6.3.4 When contacting your dealer you will be asked for the details from the warranty claim information sheet. During this time the dealer will complete the appropriate warranty claim form that will be returned along with the part. 6.3.5 When you have made contact with the dealer please follow their instructions. 6.3.6 If you are unable to contact a dealer you may wish to contact UWL directly. To contact the Service Manager either call our UK office on +44 (0) 1732 455753 or email [uw@underwaterlights.com](mailto:uw@underwaterlights.com). 6.4 If you are unable to locate a dealer close by or the units were purchased directly from UWL: 6.4.1 Before making contact we ask that you follow the troubleshooting chart for your product, when following the appropriate troubleshooting chart we find that it is helpful to complete the appropriate warranty claim information sheet. Copies can be found in the troubleshooting section of the manual included with the product or alternatively it can be download from our website ([www.underwaterlights.com](http://www.underwaterlights.com)). 6.4.2 If after following the troubleshooting guide, you still believe that the problem still exists with our product you will need to contact the Service Manager at UWL. Please contact the Warranty Department at our UK Head Office at: Underwater Lights Limited The Great Dunton Forge, London Road, Dunton Green, Kent, United Kingdom, TN13 2TD Tel: +44 (0) 1732 455753 Fax: +44 (0) 1732 743233 Email [uw@underwaterlights.com](mailto:uw@underwaterlights.com) 6.4.3 When you make initial contact you will be required to provide the information recorded on the warranty claim information sheet and have the copy of your purchase invoice for the products. You will also be required to send photographs of the unit along with photographs of the area which the units are installed. The Service team will review with you your problem and where possible advise on any further checks that may be required. If the test results show you do have a problem, you will be issued with a Warranty Claim number. The Claim number (WC#) is unique to your claim and should be used in all correspondence and attached to the returned parts. 6.4.4 You will be required to return the faulty part with the attached WC number to the address provided to you. 6.4.2. The return of the part is at your expense. 6.4.5 The part will be investigated and if the cause is established to be a manufacturing error with the components is found we will return a replacement part to you. 6.4.6 If you require a part urgently from us, you would be required to purchase a new one from us. You then have a maximum of 30 days to return the faulty part to us. We will investigate and if the product has a problem due to our manufacturing, we will provide a full refund. If you do not think that you can return the part to us within the 30 days please contact the Service Manager. If the product is not returned within the time limit without speaking to the Service Manager to obtain an extension to the 30 days, the claim will be closed and no refund given. 6.4.7 If we are unable to find a problem with the part, we will inform you of the outcome. We can provide guidance to possible reasons for the fault. UWL is not liable for or can fix problems with equipment & installations that are not purchased from UWL. The returned product can be returned to you at your request.

**Underwater Lights Limited**  
The Great Dunton Forge, London Road,  
Dunton Green, Sevenoaks, Kent, TN13 2TD UK.  
T: +44 (0) 1732 455753 • F: +44 (0) 1732 743233  
E: [uw@underwaterlights.com](mailto:uw@underwaterlights.com)  
[www.underwaterlights.com](http://www.underwaterlights.com)

**Underwater Lights Limited**  
The Great Dunton Forge, London Road,  
Dunton Green, Sevenoaks, Kent, TN13 2TD UK.  
T: +44 (0) 1732 455753 • F: +44 (0) 1732 743233  
E: [uwl@underwaterlights.com](mailto:uwl@underwaterlights.com)  
[www.underwaterlights.com](http://www.underwaterlights.com)

© 2025 Underwater Lights Limited All Rights Reserved.

Underwater lights limited reserves the right to change specifications without notice.