













QT-LED

QTE-140-HP3

FOR ALUMINIUM AND STEEL HULLS

KEY FEATURES:

-  **Maintenance**
Inside the hull
-  **Control Option**
DALI & On/Off
-  **Driver**
External
-  **Lens and test pressure**
S.S-100 Bar / **Alu-60 Bar**
-  **Power**
110-240 VAC
-  **Installation**
Weld-in
-  **Hull Material**
Aluminium & Steel
-  **Boat Size**
30 metre +
-  **Lumens**
20,000
-  **Kelvin**
6500
-  **Beam Angle**
120 Degrees

140mm



Colour:



WHITE

BLUE

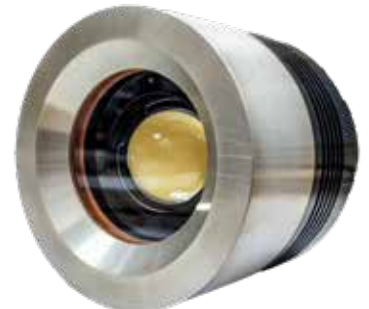
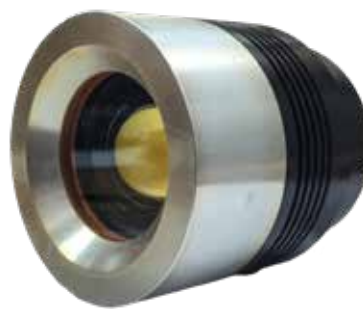

- The QTE-140 shown above is a new development of our QTS-75 both having the universal adjustment ball.
- The QTE-140 has a much larger lens aperture using a high impact borosilicate glass lens (test pressure to 100 bar).
- The QTE-140 has 120 degree LED beam and is welded flush to the hull.
- Never feel trapped by this fixture. The LED BALL has universal adjustment and is designed to use white, blue and RGBW colour configurations. The LED projector can easily be removed for servicing without the hassle of hauling your boat.
- The QTE-140 power supply to the driver is 110-240 VAC.
- The QTE-140 has Lloyds, ABS, RINA and DNV approval.
- The QTE-140 is suitable for welding into steel and aluminium hulls. All inserts are machined by Lloyds 3.2 Certificate material and individually stamped.
- The QTE-140 insert is suitable from horizontal to 45 degree hull angles.



QT-LED

QTE-140-HP3

FOR ALUMINIUM AND STEEL HULLS

THRU-HULL LED SERVICED FROM INSIDE

MOUNTING

Hull Material	Aluminium & Steel
Boat size	30 metre +
Spacing	1.5-2.5m for transom & 2.5-6m for P&S
Beam Angle	120 degrees

TECHNICAL

Lumens	20,000
Kelvin	6,500
Typical LED Life Expectancy	40,000 hrs
Min-Max Operating Voltage	110-240VAC
Current Amp Draw	1.4A-0.7A
Driver Type	External
Driver Output	55 VDC- 2.8A
Driver Watts	150 Watts
Control Option	DALI & On/Off
Bonding	Welded
EMF Earth Leakage	0.27mA/19.5mV
Primary Test Pressure S.S & ALU	100 bar – 40 bar
Secondary Test Pressure S.S & ALU	8 bar – 8 bar

PHYSICAL

Length & Diameters	See opposite
Removal Space Required	100mm (4")
Total weight	SS 12.7KG ALU 9.1KG
Driver Dimensions	220x120x90mm
Cable Lengths	6 metres up to 18m
Material - Weld in	3.2 5083 Aluminium 3.2 316L Stainless Steel
Glass Lens	Borosilicate Glass



QTE 140 WELDING INSERT

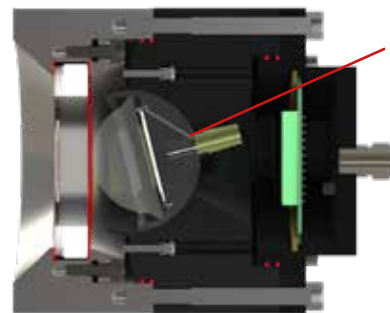
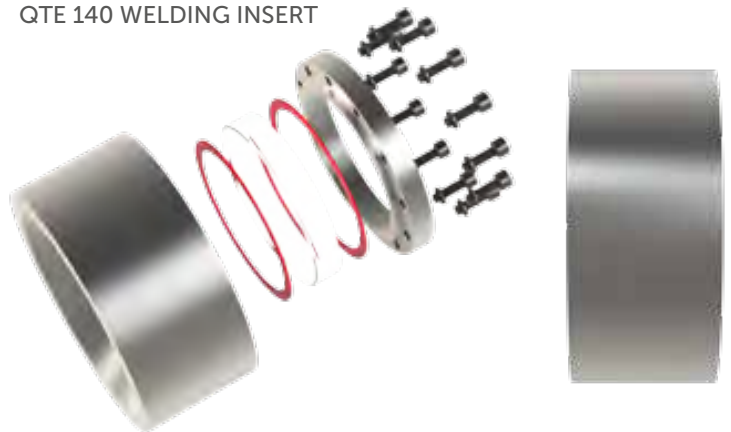

UNIVERSAL BALL ADJUSTMENT



VALID FROM AUGUST 2025

The Great Dunton Forge, London Road Dunton Green,
Sevenoaks, Kent TN13 2TD UK
T: +44 (0) 1732 455753
E: uwl@underwaterlights.com
UNDERWATERLIGHTS.COM

UWL
The art of superyacht lighting

VAT NO: 5564425 31
Registered in England No: 2348038

©2025 Underwater Lights Limited All Rights Reserved.
Underwater lights limited reserves the right to change specifications without notice.